



EVALUATION OF LOW COST MICROPHONES FOR ACTIVE NOISE CONTROL IN DUCT

Lima, P. H. R.

cefas_hrl@hotmail.com

University of Brasília – Faculty of Technology Mechanical Engineering Depto – Group of Dynamic Systems (GDS)

Campus Universitário Darcy Ribeiro – Asa Norte 70.910-900 – Brasília, DF, BRAZIL

Vieira, L.

lucassouza0@hotmail.com

Federal Institute of Goiânia – Depto IV – Mechanical Engineering

Campus Goiânia – Rua 75, nº46. Centro 74055-110 – Goiânia, GO, BRAZIL

Oliveira, E. L.

elo@ifg.edu.br

Federal Institute of Goiânia – Depto IV – Mechanical Engineering

Campus Goiânia – Rua 75, nº46. Centro 74055-110 – Goiânia, GO, BRAZIL

Abstract. *Economic feasibility and cost minimizing of experimental setups is one of the most important factors in many research and this is no different for active noise control (ANC) in ducts. Cheaper acquisition and assembly of equipment is desirable, provided you keep the same efficiency of acquisition, filtering, control and attenuation. This study aims to compare the performance of low cost microphones with precision microphones, when applied to the acoustic control system in feedforward configuration. This system makes use of a control board with Digital Signal Processor (DSP) in order to identify, analyze and compare systems of acoustic control in real time. To validate the performance of the sensors, an experimental bench was setup which included a PVC duct and speakers as noise source and actuator. Microphones are the error and reference sensors. The system performance is obtained by a sound pressure meter acting on the outlet duct.*

Keywords: *Acoustic, Low cost sensor, DSP, Active noise control*

1 INTRODUCTION

Active Noise Control (ANC) reduce sound pressure levels (SPL) and is a system that involves acoustic concepts, components and electronics. It is based on the generation of a signal "anti noise" of equal amplitude and opposite phase, superimposed to the primary sound (unwanted sound), resulting in attenuation or cancellation of both. According to Bistafa (2011), the performance of the cancellation of the primary noise depends on the accuracy in amplitude and phase of the generated anti noise. Figure 1.1 shows the superposition of two sound waves, which results in a sum of zero or attenuated value.

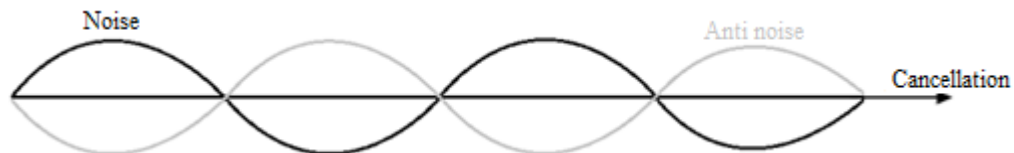

Figure 1.1 - Sum of sound waves resulting in the cancellation of both.

The ANC system acts with great efficiency at low frequencies and have a reduced installation volume. This system may have various applications and can be used together with a passive technique, resulting in hybrid control solutions (Riyanto, 2007).

An active control system was adjusted to attenuate noise in duct. Will be presented a comparison between precision microphones and inexpensive microphones when applied to this system.

2 ACTIVE NOISE CONTROL

One of the most important types of active noise controllers are the feedforward controllers. It is used on the cancellation of both narrowband noise (periodic noise) and broadband noise (random noise) (Minguez, 1998). Another important factor is that the feedforward control the reference noise is felt before spreading through the speaker of cancellation (Widrow, 1985).

2.1 Feedforward control

A significant amount of broadband noise is produced in ducts such as those generated by ventilation and exhaust systems. A simple feedforward control system scheme which operates in broadband can be seen in Fig. 2.1.

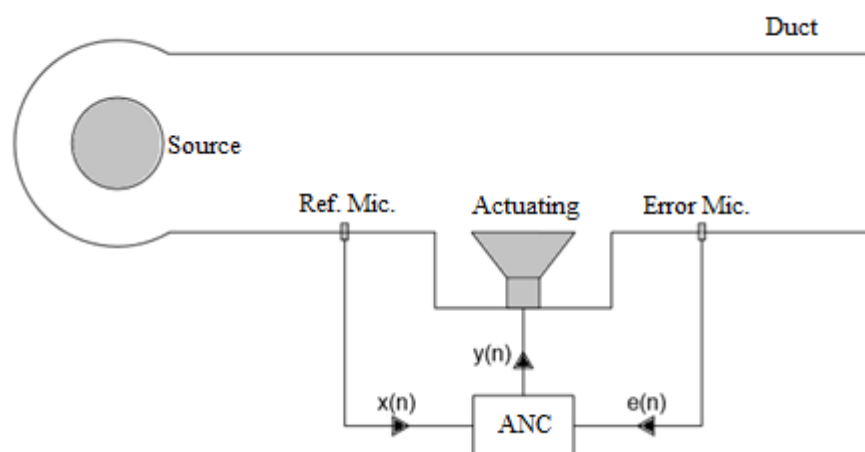

Figure 2.1 - Diagram of a feedforward controller broadband.

In this configuration the reference sensor captures the unwanted signal at an earlier point source control then feeds a controller to obtain the noise cancellation at a later point. In other words, a reference signal is measured by a microphone near the noise source before it moves over the loudspeaker. The digital controller uses the reference signal to generate a signal of equal amplitude and opposite phase of the incident signal. The anti noise signal is used to guide the speaker to produce a canceling sound that attenuates the primary acoustic noise in the duct.

The basic principle of feedforward control system is that the propagation delay of the sound wave between the reference microphone and speaker, offers sufficient time to calculate the control and activate the anti noise, thus causing the cancellation. So that the distance between the reference microphone and canceling speaker satisfies the principle of causality.

The main goal of the feedforward controller is to anticipate the physical phenomenon in a predictive way through the information captured by the reference sensor, so that the noise is canceled when going through error sensor.

The residue, ie, the error signal measured by the error microphone is basically used as a performance index of the controller to adapt the filter coefficients.

2.2 Algorithm of adaptive filtering

The active noise controllers normally constitute the following elements: sensors, actuators, plant and controller. And the term "active" is used to distinguish this technique of the classic or passive control, where the noise is absorbed or reflected by passive materials. Devices that compose a passive control system have the characteristic of not providing power to the system, (Oliveira, 2012).

Sensors and actuators are administered through an electronic unit (controller) designed for cancellation of unwanted noise in the plant, which is based on the principle of wave superposition. It mostly consists of generating an anti noise same amplitude and opposite phase to the unwanted noise in order to cause the cancellation of the noisy signal at a given point or region of interest (Nelson, 1987)(Hansen, 1997).

Although conceptually simple, there are several difficulties to be overcome when installing this type of controller. Significant variations in environmental conditions and non-linearity of the sensors and actuators can hamper and even compromise the controller's efficiency because introduce unwanted disturbances in the system (Kuo, 1999) and change the algorithms of the transfer functions.

In an attempt to counteract these disturbances and alterations, the researchers developed the automatically adaptive controllers. These are inserted in adaptive filters in digital signal processors (DSPs) that promote, through adjustment of its coefficients, the noise reduction system (Goodwin, 1984)(Clarkson, 1993). For this procedure the filter normally used is the type Finite Impulse Response (FIR) and the mechanism normally used in the setting of the filter coefficients are versions of variants LMS (Least Mean Square) classic. In this case we used the LMS algorithm along with FxLMS algorithm.

The active noise control reached a stage of development such that commercial systems are now available in major practical applications (Qiu, 2014).

2.2.1 Control system

In ventilation and exhaust systems a wide range of broadband noise is produced in their ducts. Such systems are evaluated by the construction of similar systems in laboratories compounds commonly by a noise source (noise generator), a reference sensor (microphone), an actuator (speaker), an error sensor (microphone) and an electronic of control. In Fig. 2.2 we define each component of an ANC system and acoustic systems involved.

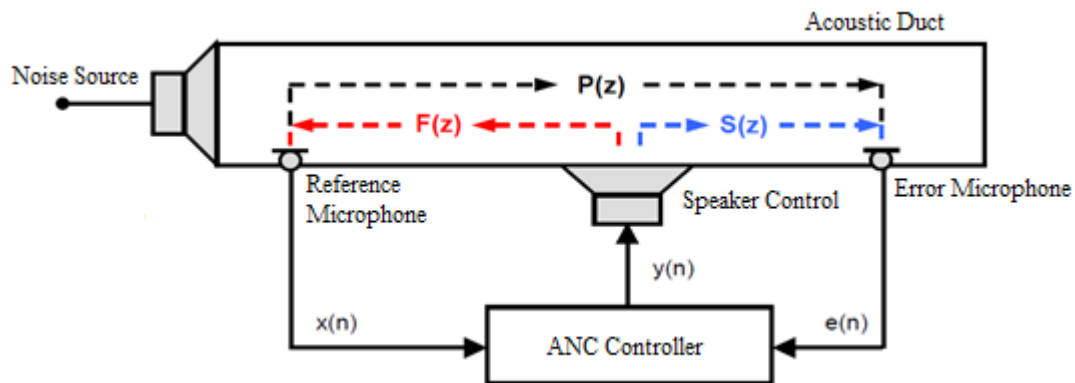

Figure 2.2 - System of an active noise control (feedforward).

Where $x(n)$ is the reference signal of the controller, $y(n)$ is the controller output signal, $e(n)$ the error signal, $P(z)$ the transfer function between the noise source and the microphone error (primary path), $S(z)$ is the transfer function between the actuator and the error microphone (secondary path) and $F(z)$ is the transfer function between the actuator and the reference microphone (feedback path).

As shown in this configuration, the reference microphone picks up unwanted signal at a later point the noise source, and generates $x(n)$, before this signal passes through the actuator. This signal $x(n)$ is processed by the ANC controller, which in turn generates a control signal $y(n)$ of equal amplitude and opposite phase of the incident signal, to the actuator. Where the signal $y(n)$, anti noise, is used by the actuator to produce a canceling sound that attenuates the primary acoustic noise in the duct. The error microphone generates a signal $e(n)$ used to monitor controller performance.

It is known that in acoustic it's not possible to zero out the noise completely, just bring to an acceptable level. Therefore it is impossible to reduce this error by 100%. However, it is possible to obtain values of this error in the control system capable of attenuating the sound pressure level in dB 20, 30, 40, ..., when compared with the sound pressure level of the system without the controller action.

2.3 Application of active noise control

ANC systems are constantly being improved and deployed in commercial applications in several areas. The most famous is the headset that uses the active control and passive (reinforced plastic coating on the shell). In this application, active systems usually have attenuation in the range of 10-15dB for frequencies up to 500 Hz (Kuo, 1999). Another application that commonly uses the ANC is in control of plane waves propagating in ducts, mainly for its viability. The ANC is also used for noise control indoors. There are systems with only one source of control, producing mitigations that reaches 15 dB in a specific area of rooms (Kuo, 1999). It also applies to power transformers, although so far not reached an adequate attenuation in all directions of the transformer.

3 MICROPHONES

The microphones are critical components to identify the noise. Because they are one electroacoustic transducer, they are responsible for transforming sound waves into electrical signals. This enables the handling and processing of these signals by means of electronic components, and can thus amplify, filter and store these signals.

There are several types of microphone, with different principles of operation. Existing principles are: varied contact resistance, electrodynamic, piezoelectric and electrostatic. But all microphones are based on the conversion of a mechanical wave in a proportional electrical signal to this.

Each microphone has certain characteristics that are specific to certain types of applications. According to Gerges (2000), these characteristics are: frequency response curve, dynamic range, directivity and sensitivity.

The microphones studied in this work are of the electrostatic type, being three different condenser: Bruel & Kjaer type 4957 (Bruel & Kjaer, 1996), PCB 130E22 (PCB Piezotronics, 2012) and SAMSON C02 (Samson, 2014); and an electret microphone: JL- 061C.

4 DUCT DESIGN

For the verification of low cost microphones, applied to the ANC, it was necessary to draw up an experimental duct design built to carry out the activities proposed in this paper.

4.1 Project design

For the construction of a duct without high costs and complex geometries using easily accessible and inexpensive materials, it was decided to build the duct with PVC pipes.

It was designed so a duct 3.8 m in length with a diameter of 150 mm. The primary source was positioned at one end to 1.735 m speaker of cancellation. Fig. 4.1 shows the isometric view of the assembly of the duct, made in CAD software to design 2D and 3D.

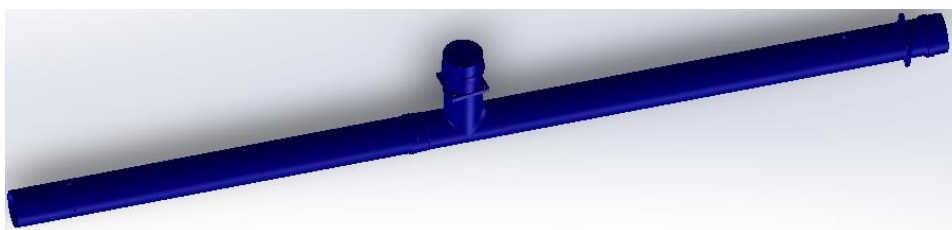

Figure 4.1 - 3D CAD design of the duct.

In Fig. 4.2, presents a side view of the duct where are identified dimensions and the instrumentation used, for example, speakers (actuators) and the reference and error microphones.

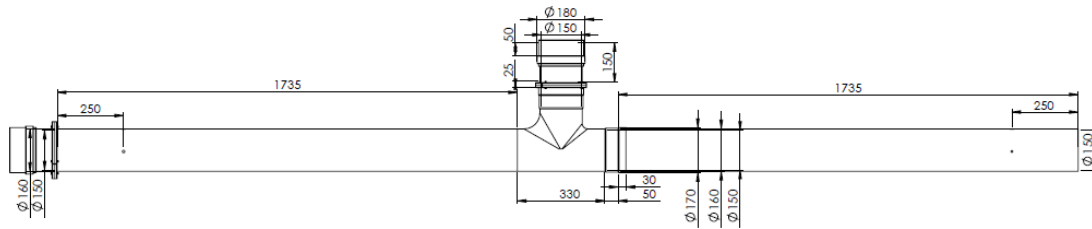

Figure 4.2 - Technical drawing of experimental set-up with microphones location.

4.2 Feature acoustic duct

In a uniform circular cross-section duct diameter d , considering the propagation environments cylindrical, the lower cutoff frequency (f_c) corresponding is given by (Delfino, 2005):

$$f_c = 1.84 \cdot \frac{c}{2 \pi \cdot d} \quad (4.1)$$

Therefore, this duct is flat acoustic waves to 672 Hz cutoff frequency, based on calculations of Eq. 4.1.

5 INSTRUMENTATION AND TECHNICAL SPECIFICATION

Four microphones of different specifications were used, a type of speaker and a DSP board.

The speakers used in this experimental procedure is the line Subwoofer Bass UBL Selenium (Harman, 2011). Model 6MB17A with a diameter of 6 inches, maximum power of 70 Watts RMS and frequency response range of 72-4000Hz.

They were used for the analysis and comparison of results, to thereby obtain the objective of the proposed work, three microphones each manufacturer. It is one as a reference microphone and two as error microphones. Different microphones previously determined, had as criteria the best frequency response and lower cost compared to expensive microphone.

In Table 5.1 below proves the criteria used to determine the microphones used in this work, based on the low cost and the best frequency response in a frequency range close to f_c . Below, you can see the price list of the microphones.

Table 5.1 - Market price of microphones

MICROPHONE	MARKET PRICE (US\$)
JL-061C	0,30
SAMSON - C02	120,00
PCB PIEZOTRONICS - 130E22	600,00
BRÜEL & KJÆR - 4957	1000,00

Since this work aims to better economic viability on an ANC system, sensors and actuators are less accurate and inexpensive. However, because the added capability of digital

signal processing in DSK C6713 platform the response obtained had the same success that a system using components with higher added value.

The DSK 6713 Board Spectrum has the following characteristics:

- DSP Texas Instruments TMS320C6713 (Texas Instruments, 2005);
- RAM memory of 16 MB (megabytes);
- Analog inputs: MIC IN and LINE IN;
- Analog outputs: HP OUT and LINE OUT.

6 EXPERIMENTAL PROCEDURES AND RESULTS

Will be presented two procedures. One for the characterization of the microphones under study aiming to determine its frequency response curve. The other procedure performed: it is the application of active noise control in the circular section duct, using different types of microphones to compare the results with each other.

6.1 6.1. Experimental Procedure I – Characterization of the microphone in the frequency domain

Characterize the frequency response curve of the microphones allows us to know the frequency range that each microphone works with more efficiency. For this, a methodology aimed at identifying and comparing the values obtained in decibels for each predetermined frequency has been prepared. The proposal is to sweep the entire range of frequency of the microphones, with emphasis on frequencies up to 500 Hz.

Using a calculation program the value of the reference sound pressure, so that the microphone PCB having, is $P_0 = 0.16896$. This value is used to calculate the SPL (L_p) of the other pre-set frequencies for all microphones in Eq. 6.1.

$$L_p = 20 \log \left(\frac{p}{p_0} \right) \quad (6.1)$$

After the treatment all signs acquired in the measurements was generated Fig. 6.1.

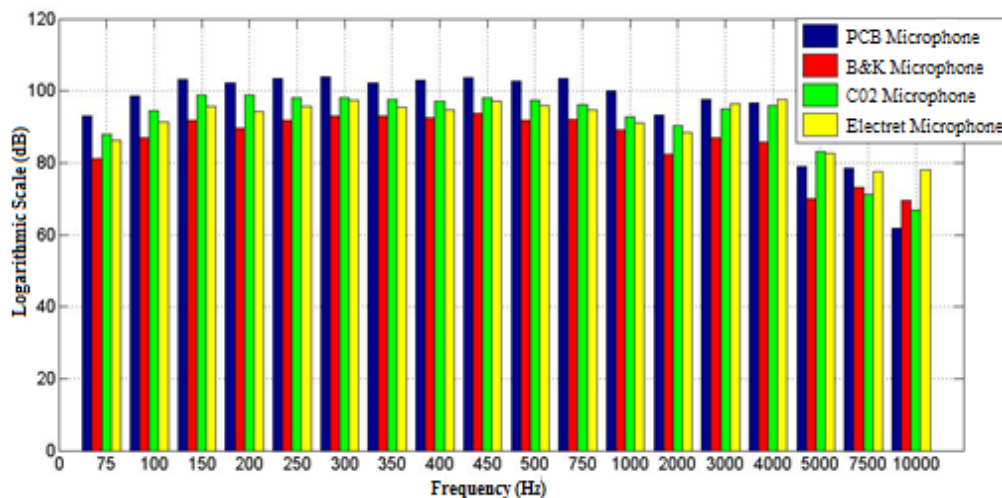

Figure 6.1 - SPL to the microphones in a study using the reference sound pressure P_0 .

Note that, as mentioned earlier, that the microphone to the PCB SPL frequency of 1000 Hz is equal to 100 dB. This enables comparison of different types of microphones studied, as reference in all other values to a single value. With it, you can see the sensitivity of each microphone, identifying the most sensitive microphone is the microphone PCB and less sensitive microphone is the microphone Bruel & Kjaer (1996).

Another feature that should be highlighted is the stabilization of values of the NSP for all microphones in the frequency range 150-500 Hz, with a variation of 2 dB for PCB and Samson microphones, but the microphones electret and Bruel & Kjaer (1996) undergo a somewhat greater variation being 3 dB and 4 dB, respectively.

The analysis of the data shown in Fig. 6.1 concludes that all microphones can be used in an active noise control system.

6.2 Experimental procedure II – Application of ANC

The evaluation of the microphones in the application of ANC aims to identify which of the microphones have better performance for this type of application.

The main parameter to be analyzed in this experiment was the attenuation obtained by applying the ANC. This was done using a sound pressure meter calibrated.

As the variable under consideration is the attenuation that the ANC causes and this calculation is performed by SPL difference before and after application of the ANC, was standardized as would be the measurements performed with the sound pressure meter. Set the position of this unit as the end of the duct, directing your microphone into the duct. Two measurements were made, prior to application of the ANC and the other measuring after application and the stabilization of the ANC. Each measurement time is 2 minutes and the results are presented in the discussion below.

The last point to be made is that the background noise in the room where we installed the product was about 50 dB at the time of measurement.

The Table 6.2 below shows the overall SPL obtained at each measurement, making the difference between the values obtained before and after applying the ANC and with this result the column labeled attenuation.

Table 6.2 - Attenuation of global SPL

Microphone	SPL before of the ANC (dB)	SPL after the ANC (dB)	Attenuation (dB)
PCB	88,7	51,9	36,8
Bruel &Kjaer	88,7	50,6	38,1
Samson	88,9	51,6	37,3
Eletreto	89,2	49,4	39,8

Observing the results we note that all the microphones were able to mitigate the noise generated significantly, reaching levels close or equal to the background noise. Through the

comparisons made by graphic confirms the decline in the SPL in octave band whose center frequency is 250 Hz, regardless of microphone used. This directly influences the results presented in Table 6.2, because the value of the global SPL depends on the value of the SPL presented in each band.

7 CONCLUSION

This study compares the performance of high and low cost microphones in a ANC system. Two microphones considered high cost were studied, Bruel & Kjaer and PCB. The microphones low cost are Samson and electret. Both microphones can be applied in the ANC to the standard conditions in this work. All microphones have similar performance. The cost benefit of using low cost microphones compared to the other is much greater. To achieve the same attenuation level, the invested monetary value is significantly lower. Comparing prices from Bruel & Kjaer microphone with electret microphone, this value can reach the order of 0.05 %.

- All microphones studied in this work are able to be applied in ANC in circular ducts with a diameter of 150 mm, where the noise source to generate a tonal signal 250 Hz;
- All microphones obtained attenuation next to the SPL of background noise, this suggests that background noise could have influenced the results obtained;
- The method used to characterize the microphones, by means of tonal signals, guaranteed way to make a comparison between these sensors. However, it is important to stress that there are several cascade systems in the experiment, such as: microphone, preamp, computer audio card, cables, among others;

REFERENCES

- Bistafa, S. R., 2011. *Acústica aplicada ao controle de ruído*. 2ª ed. Editora Edgar Blucher Ltda. São Paulo.
- Bruel & Kjaer, 1996. *Microphone handbook theory*. Vol. 1, Nearum, Dinamarca.
- Clarkson P. M., 1993. *Optimal and Adaptive Signal Processing*. Boca Raton, FL: CRC Press.
- Delfino, L. C., 2005. *Controle ativo de ruído em dutos utilizando processador Digitais de sinais*. 151 f. Federal University of Uberlândia. Uberlândia, MG.
- Gerges, S. N. Y., 2000. *Ruído fundamentos e controle*. 2ª ed. Florianópolis: NR Editora.
- Goodwin G. C. and Sin K. S., 1984. *Adaptive Filtering Prediction and Control*. Englewood Cliffs, NJ: Prentice-Hall.
- Hansen C. H. and Snyder S. D., 1997. *Active Control of Noise and Vibration*. London, U.K.: E&FN Spon.
- Harman, 2011. *Subwoofer Linha Bass, Model 6MB17A*. UBL SELENIUM, USA.
- Kuo, S. M.; Morgan, D. R., 1999. *Active noise control: a tutorial review*. Proc. IEEE Int. Symp. Circuits Syst., pp. 943-973.
- Minguez, A., 1998. *Ingeniería avanzada para sistemas de controle de ruido acústico mediante técnicas adaptativas*. Tesis Doctoral, Universidade Politécnica de Madrid.
- Nelson P. A., Curtis A. R. D., Elliott S. J. and Bullmore A. J., 1987. *J. Sound Vibration*, vol 117, n. 1, pp. 1-13.
- Oliveira, E. L., 2012. *Controle Ativo de Ruído Aplicado a Dutos com Propagação de Modos Acústicos de Alta Ordem Via Particionamento Axial*. 119 f. Federal University of Uberlândia. Uberlândia.
- PCB Piezotronics, 2012. *Icp Electret Array Microphone Model 130E22*. NY.
- Qiu, X., Lu, J., Pan, J., 2014. *A new era for applications of active noise control*. Inter Noise, Melbourne, Austrália.
- Riyanto, B., 2007. Real-time DSP Implementation of Active Noise Control for Broadband Noise Using Adaptive LMS Filter Algorithm. *International Conference on Electrical Engineering and Informatics* 718–722.
- Samson, 2014. *Microfone Condensador C02 – Manual do usuário*. Equipo.
- Texas Instruments, 2005. *SPRS186L - TMS320C6713 Floating-point Digital Signal Processing*.
- Widrow, B. and Stearns, S. D., 1985. *Adaptive signal processing*. Englewood Cliffs, NJ: Prentice-Hall.